



# NORDIK HVLS HYPERBLADE RANGE

REVERSIBLE INDUSTRIAL CEILING FANS





**VORTICE S.p.A.** is part of a multinational group,<sup>[1]</sup> **VORTICE GROUP**, which operates through its own companies or local distributors in over 90 countries worldwide and has a rich product portfolio that guarantees air quality and climate comfort. The headquarters of VORTICE S.p.A are in Tribiano (Milan).



VORTICE GROUP also includes:

<sup>[1/2]</sup> **BUSINESS UNIT INDUSTRIAL**, born from the acquisition in 2010 of Loran srl, based in Isola della Scala (VR). 2024 become Vortice's BUSINESS UNIT INDUSTRIAL.

<sup>[3]</sup> **VORTICE LIMITED**, the UK subsidiary of VORTICE S.p.A., established in 1977 and based in Burton on Trent.

<sup>[4]</sup> **VORTICE VENTILATION SYSTEM**, a company inaugurated in 2013 with headquarters in Changzhou, China.

<sup>[5]</sup> **CASALS VENTILACIÓN AIR INDUSTRIAL S.L.** historic Spanish brand, based in Sant Joan de les Abadesses, Girona, acquired in 2019.

<sup>[6]</sup> **VORTICE LATAM S.A.**, based in Alajuela in Costa Rica, established in 2012.

<sup>[7]</sup> **VORTICE POLSKA** new representative office in Warsaw, Poland, established in 2026.

## NORDIK® HVLS HYPERBLADE

Reversible Industrial ceiling fans



## Regulatory standards

Industrial ceiling Ventilation products NORDIK HVLS HYPERBLADE are compliant with the following Directives and Standards in their most recent versions:

- Machinery Directive: No. 2006/42/EC
- Electromagnetic Compatibility Directive: EMC 2014/30/UE
- Eco-Design Directive for electric motors No. 1781/2019/EC
- The safety of all models of the NORDIK HVLS HYPERBLADE series is certified by ETL according to UL 507 and CSA 22.2 standards

# NORDIK HVLS HYPERBLADE

## Industrial fans

Ceiling fans available in 5 different sizes; with 300, 400, 500, 600 and 700 cm in diameter.

Equipped with EC (brushless) motors for high performances, low consumption and low noise emissions. Perfect for cooling and keeping temperature balance in wide areas.



4

**NORDIK HVLS HYPERBLADE 300/120" M SVT** cod. 61181  
**NORDIK HVLS HYPERBLADE 300/120" T SVT** cod. 61186  
**NORDIK HVLS HYPERBLADE 400/160" M SVT** cod. 61182  
**NORDIK HVLS HYPERBLADE 400/160" T SVT** cod. 61187

**NORDIK HVLS HYPERBLADE 500/200" T SVT** cod. 61188  
**NORDIK HVLS HYPERBLADE 600/240" T SVT** cod. 61189  
**NORDIK HVLS HYPERBLADE 700/280" T SVT** cod. 61190

### **KEY:**

**M** = Single-phase motor

**T** = Three-phase motor

# WHY INSTALL NORDIK HVLS HYPERBLADE

Because it allows the achievement of significant benefits  
in both summer and winter:

## SUMMER OPERATION:

As it is known, high temperatures and high relative humidity levels make environmental conditions uncomfortable and, in some cases, they can affect the occupants' productivity. Under normal conditions the human body feels the need to transfer heat from room temperatures above about 23 °C.

Compared to air conditioners, which reduce the room temperature, fans, favour the cooling by convection and evaporation of sweat at the same temperature.

## WINTER OPERATION:

Warm air, less dense than cold air, accumulates near the ceiling, resulting in a phenomenon known as "stratification". The adoption of fans capable of pushing warm air downwards performs the reshuffling ("destratification") useful to overcome the problem, guaranteeing significant savings both in terms of lower energy dissipation through walls and roof, and reduced caloric intake necessary for the maintenance of adequate temperature levels at occupant level.

## BENEFITS OF INSTALLING NORDIK HVLS HYPERBLADE:

The use of ceiling fans of the NORDIK HVLS HYPERBLADE series, which has a high (IP65) degree of resistance to water and dust, offers a wide range of temperatures in continued operations (-10 °C to +50 °C) and speed regulations.

They are particularly suitable for industrial environments (such as warehouses, depots, stables, etc.), where the use of air conditioning systems would be impossible or too expensive, as well as for commercial areas (such as supermarkets, gyms, airports, etc.), where their action allows significant savings in connection with the amplification of the effects of any already existing air conditioning systems and thanks to air destratification.

# NORDIK HVLS HYPERBLADE

LARGE diameters for wide areas, nominal up to 7 m Ø:

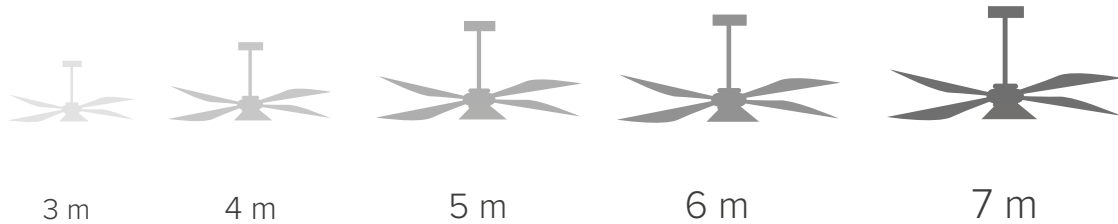

6

- High reliability even in particularly demanding operating conditions: the adoption of EC motors, efficient, virtually maintenance-free and intrinsically adjustable, makes the use of mechanical gearboxes useless.
- Easy and quick to install, thanks to the system for fixing the blades to the engine, designed to facilitate coupling and thus reduce errors that could cause damage to the components.
- Reversibility (the operation of the products is optimised to generate a downward flow of air, but the product control system also allows them to rotate in the opposite direction, in cases where it is preferred to avoid a current of air directed towards the occupants).
- Low specific consumption, perfectly compatible with intensive use.
- Particularly low sound emission levels.
- Wide operating temperature range (-10 °C / +50 °C)
- High (IP65) rating level against dust and water, suitable for use Industrial applications.
- Anodised blades for high resistance to corrosion and abrasion.
- Specially designed motor, rotor (e.g. blades made of one piece and therefore less subject to failure or breakage over time) and integrated electronics for greater reliability over the time.
- Ready for integration into the BAS (Building Automation System) Communication protocol Mod Bus RTU.
- Compatible with a wide set of control and regulation devices.
- Standard and optional installation kits for total safety of installation and use.

# NORDIK HVLS HYPERBLADE

## INSTALLATION

Support rod, brackets and bolts supplied as standard.

7

## EC MOTORS

Synchronous brushless type with permanent magnets (EC), integrate the relevant drivers and are designed to combine high performance, proportionally reduced consumption and wide speed regulation ranges. M models are characterised by single-phase power supply (100-240 V / 50-60 Hz), T models by three-phase (200-480 V / 50-60 Hz). All feature a high (IP65) degree of protection from dust and water, making them perfectly compatible with use in particularly demanding conditions.

## BLADES

Made of anodised Al, they achieve high efficiency values in downwash operation (generated air flow facing downwards) and ensure particularly low sound emission levels thanks to the sophisticated NACA aerodynamic profile. Each one mounts a winglet to increase its aerodynamic efficiency, decreasing drag induced by the tip vortices and containing the noise emissions.

# APPLICATIONS

Designed for installation at a minimum distance from the target ceiling equal to 1.5 m, they reach maximum effectiveness installed at about 4 m from the ground. Under these conditions, the useful area is approximately 3 times the diameter of the product.



STORAGE

HANGAR



SUPERMARKETS



# APPLICATIONS



AIRPORTS

STABLES



LOGISTICS WAREHOUSE

## TECHNICAL CHARACTERISTICS

### Available models

- 7 models: available in 5 diameters (300, 400, 500, 600 and 700 cm).
- Made of anodised Al, they achieve high efficiency values in downwash operation (generated air flow facing downwards) and ensure particularly low sound emission levels thanks to the sophisticated NACA aerodynamic profile. Each one mounts a winglet to increase its aerodynamic efficiency, decreasing the induced resistance induced by the tip vortices and containing noise emissions.

### Motors

- Synchronous brushless type with permanent magnets (EC), integrate the relevant drivers and are designed to combine high performance, proportionally reduced consumption and wide speed regulation ranges. M models are characterised by single-phase power supply (100-240 V / 50-60 Hz), T models by three-phase (200-480 V / 50-60 Hz). All boast a high (IP65) degree of protection from dust and water, making them perfectly compatible with use even in particularly demanding conditions.

### Electronics

Power and control electronics

Housed in the aluminium casting containing the motor, to grant adequate protection from water and dust, electronic controls to manage power supply and fine adjustment of speed according to the specific needs.

The NORDIK HVLS HYPERBLADE electronics are complete with EMI/EMC filters for preventing the risks related to electromagnetic interference, and include:

- Opto-insulated RS485 connector for integration into the BAS (Building Automation System) Modbus RTU communication protocol
- An isolated analogue input, for regulating the fan speed through an external potentiometer or other device operating with 0-10 V signal.

The safety systems integrated into the electronics (drivers) include protection against overcurrent, short circuits, overtemperatures, overvoltages and undervoltages and anti-disturbance filters, in accordance with current international standards for safety and electromagnetic compatibility.

In accordance with NFPA 72 requirements as per US National Fire Protection Agency, the fan control system forces shutdown and immediate blocking upon detecting a water flow signal from the fire alarm system, so as not to affect the effectiveness of the devices (sprinklers) that may have been installed.

### Kits

- Kit for ceiling installation.

Each fan is supplied with a complete installation kit consisting of a rod, with a standard length of 1.5 m, a pair of brackets and the related metal hardware. Fully made of steel, this kit ensures the right and solid installation of the device on the target ceiling in the most common installation methods.

- Tie-rod kits

optional kit consisting of 4 tie rods specifically designed for an additional degree of axial stability, useful whenever the fan is subject to an external stress (e.g. strong wind), or when the target floor does not meet the necessary requirements of solidity, in relation to the weight of the product and the stresses induced by its operation.

In particular, the usage of the HYPERBLADE-RD HVLS Kit is to be considered mandatory when the position chosen for the installation of the fan exposes it to wind gusts, to the risk of accidental collisions with machines or equipment moving in its, to the possible impact of birds or, again, is located in a seismic area or otherwise subject to appreciable vibrations (e.g. industrial processes involving the use of power hammers, industrial presses, etc.).

### Motor's IP rating:

- IP65

Technical data

PRODUCTS	CODE	V~50/60 HZ	W MAX	A	IP	°C MAX	RPM MAX	MAX FLOW RATE		Ø m	N° OF BLADES	KG
								m³/h				
								AMCA 230-2023	AMCA 230-1999			
NORDIK HVLS HYPERBLADE 300/120° M SVT	61181	100-240V 50/60	410	1.5 - 5	65	50	140	79.400	112.287	3	5	76
NORDIK HVLS HYPERBLADE 300/120° T SVT	61186	200-480V 50/60	500	0.9 - 1.8	65	50	140	79.400	112.287	3	5	76
NORDIK HVLS HYPERBLADE 400/160° M SVT	61182	100-240V 50/60	290	1.3 - 3.5	65	50	75	103.000	145.663	4	5	86
NORDIK HVLS HYPERBLADE 400/160° T SVT	61187	200-480V 50/60	300	0.7 - 1.1	65	50	75	103.000	145.663	4	5	86
NORDIK HVLS HYPERBLADE 500/200° T SVT	61188	200-480V 50/60	730	1.2 - 1.9	65	50	80	205.000	289.911	5	5	126
NORDIK HVLS HYPERBLADE 600/240° T SVT	61189	200-480V 50/60	850	1.4 - 2.8	65	50	60	253.800	358.924	6	5	136
NORDIK HVLS HYPERBLADE 700/280° T SVT	61190	200-480V 50/60	790	1.3 - 2.5	65	50	50	330.800	467.817	7	5	156

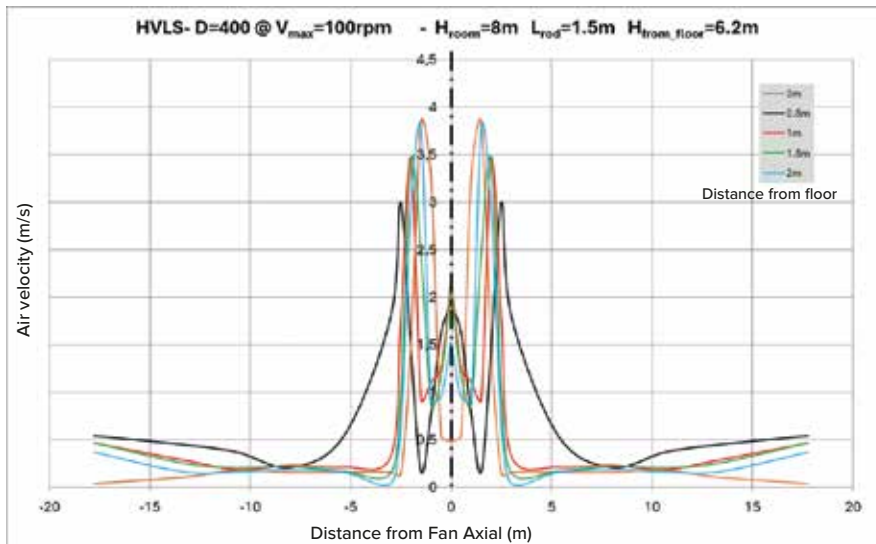

In many applications, the effectiveness of an HVLS fan depends on the speed of the air flow generated; this varies, with the same fan diameter and installation height, with the distance from the axis and blades. The picture shows this trend in the case of a NORDIK HVLS HYPERBLADE 400/160° installed 6 m above the ground, in the absence of obstacles (machinery, racking, transverse air flows, etc.) which may in turn influence the result.

## Dimensional data

TYPE A

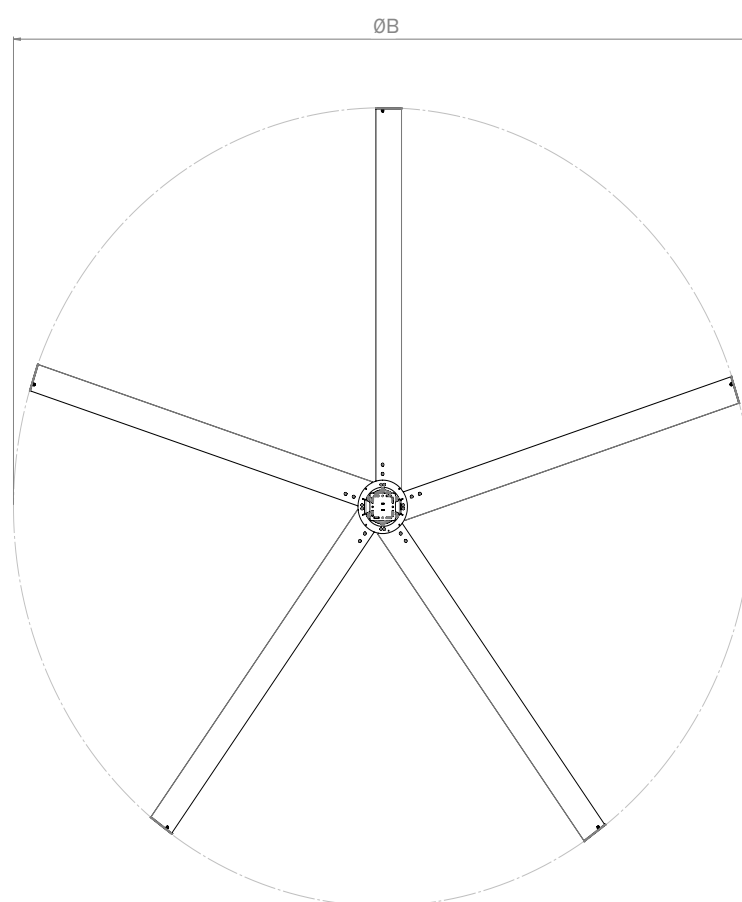
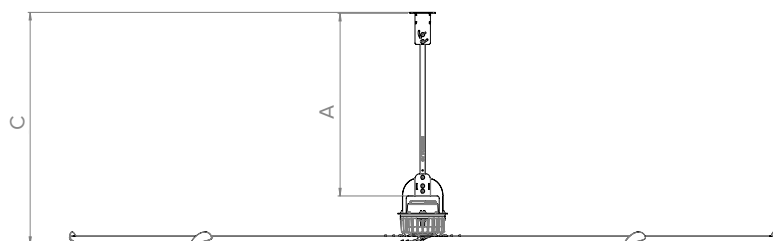

12

PRODUCTS	CODE	TYPE	A	ØB	C
NORDIK HVLS HYPERBLADE 500/200" T SVT	61188	A	1600	4950	2015
NORDIK HVLS HYPERBLADE 600/240" T SVT	61189	A	1600	5950	2015
NORDIK HVLS HYPERBLADE 700/280" T SVT	61190	A	1600	6950	2015

Dimensional data

TYPE B

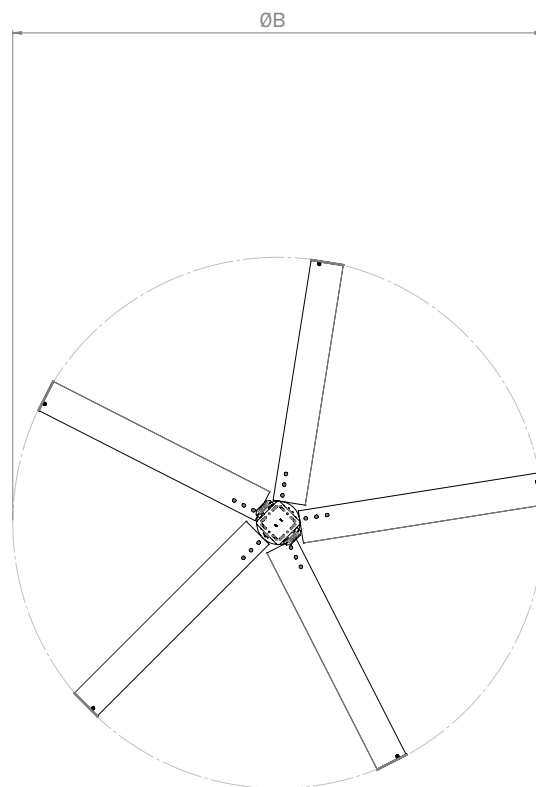
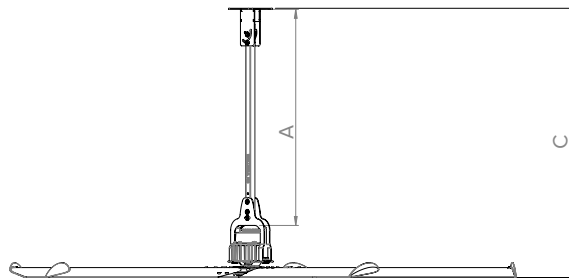

PRODUCTS	CODE	TYPE	A	ØB	C
NORDIK HVLS HYPERBLADE 300/120" M SVT	61181	B	1600	2950	1995
NORDIK HVLS HYPERBLADE 300/120" T SVT	61186	B	1600	2950	1995
NORDIK HVLS HYPERBLADE 400/160" M SVT	61182	B	1600	3950	1995
NORDIK HVLS HYPERBLADE 400/160" T SVT	61187	B	1600	3950	1995

## Control units

**Code 20151 VORT T-HCS**



Specifically designed for the zootechnical industry, the VORT T-HCS control unit is an optional, wire-connected control device with an LCD display, capable of automatically monitor the fans connected based on temperature values, relative humidity, and THI (Temperature Humidity Index), the bioclimatic index that combines the simultaneous effect of temperature and relative humidity and is used to determine heat-induced stress in the livestock. VORT T-HCS allows the automatic management (ON/OFF up to 4 strokes) of the optionally installed cylinders, the limitation or interruption of the ventilation upon start, and the management of the auxiliary ventilation systems, if any. Alternatively, fan speed and cylinder control can be manually adjusted, regardless of climatic conditions, e.g. for testing the proper functioning of the system during installation or trial.

**Code 21137 VORT T**



Wire-connected control unit, with LCD display capable to manage up to 20 units, VORT T allows to automatically control the speed of the connected fans based on the readings of the temperature sensor and an optional anemometer, increasing or decreasing fan's speed according with the room temperature or, alternatively, based on the wind speed (for, useful for units installed in stables whose walls have wide outwards openings).

Alternatively, the fan speed can be manually adjusted, regardless of climatic conditions, e.g. for testing the proper functioning of the system during installation or trial.

**Code 20152 VORT T-PLUS**



Vort T-PLUS is a device specifically designed for the accurate control of the microclimate of livestock farms. The onboard microcontroller (PLC) has an intuitive user interface with an 8-keys keypad and allows, the sequential programming of the operation of the individual devices installed according to the values of temperature, humidity and wind speed detected.

In particular, VORT T-PLUS:

- controls the wind speed, stopping ventilation in case of need/opportunity
- manages the ventilation intensity, operating (0 to 10-V signal) the EC motors of the connected fans
- detects temperature and THI values
- controls up to 4 cylinders with 4 on-off programmable levels
- controls humidity by blocking cylinder commands, if needed
- manages temperature and THI alarms
- allows hourly programming.
- communicates with VORT MASTER through the integrated RS-485 port

The enclosure, in the standard DIN 9 module format, simplifies its installation inside switchboards.

The 8-segment display is easily readable; the operating states of the connected products are represented by special LEDs.

Code 20153

**VORT MASTER**



Specifically designed to be used in the zootechnical industry, the VOLT MASTER control unit guarantees the monitoring of the microclimate in cattle breeding facilities (up to 12 areas and 12 lines) by managing each fan, cylinder, (temperature and amperometric) alarms based on temperature, humidity, THI, air speed, and other values detected by the sensors installed. It is also possible to programme functioning hours and durations for the shutdown of utilities. The graphical interface of the touch LCD panel facilitates real-time control of the correct operation of the system. A password ensures unwanted, while an adequate internal storage space allows consumption analysis, storage of operating data and recording (datalogging) of events. A USB port also allows connection to a camera. Through the ethernet port, VORT MASTER can be connected to a network and remotely controlled; at the same time, the VNC (Virtual Network Computing) technology allows its quick and easy connection to smartphones, tablets, and personal computers

**Regulators**



**POT Code 12828**

Potentiometer for fan regulation using 0 to 10-V signal.



**POT-I Code 12832**

Potentiometer for fan regulation via built-in 0-10V signal.

**TEMP-NTC 10K Cod.20750**

Temperature probe compatible with VORT T, VORT T-HCS and VORT T PLUS control units.



**POT DIG Cod.20840**

POT DIG» is a digital potentiometer for regulating the operating speed of the fans from the NORDIK HVLS

- Fans speed percentage adjustment (settable value: from 0% to 100% / OUTPUT: 0-10V).
- Reverse mode activation («R.V» button).
- Switching off ('OFF' displayed on screen): the connected fans stop (speed value=0%).
- Operating temperature: -10...+55°C.

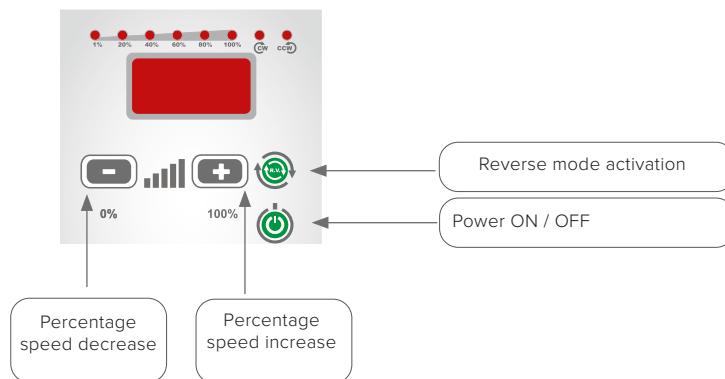

## Accessories



### **USB-C Code 21198**

ModBus USB converter that can be combined with the VORT control unit, useful for remote management of the fan(s).



### **WP Code 21197**

External anemometer connectible to VORT T control unit, useful to automatically control the fan in case of wind gusts.

### **C-RH Code 13113**

RH sensor can be combined with VORT T-HCS and VORT T PLUS controllers

### **TEMP - NTC 10K Code 20750**

Temperature probe for combination with VORT T, VORT T-HCS and VORT T PLUS controllers

### **BOX PLUS Code 22994**

Transport crate (2000x770x768) mm

### **BOX PLUS Code 22995**

Transport crate (2500x770x768) mm

### **BOX PLUS Code 22996**

Transport crate (3000x770x768) mm

### **BOX PLUS Code 22997**

Transport crate (3500x770x768) mm

## Suspension tie-rods kit

Code 20193

### **HVLS HYPERBLADE tie-rod kits - RD**

Optional kit including four tie-rods, designed to ensure a solid and safe installation.



This kit is mandatory in case of:

- strong wind;
- risk of accidental impact with machines or other objects moving close to the ceiling fan;
- presence of birds;
- installation in seismic zones or other areas with vibrations (e.g. industrial processes involving the use of hammers or industrial presses).

Code 20716

### **HVLS HYPERBLADE-PL3**

Pole, 3m long, for installation on high ceilings

## Filters

Code 20751

### **F-RS485**

FC interference filter with direct insertion for VORT T PLUS control unit

Code 20752

### **F-RS485 DIN**

DIN rail mounted RC interference filter for VORT T PLUS control unit

## Anchor brackets

Code 20267

**STF 1**

Bracket for anchorage to steel beams. Option 1

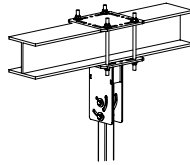

Code 20268

**STF 2**

Bracket for anchorage to steel beams. Option 2

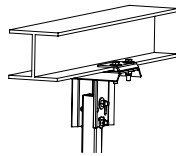

Code 20269

**STF 3**

Bracket kit for anchorage with existing structure 3m-5m. Rod not supplied

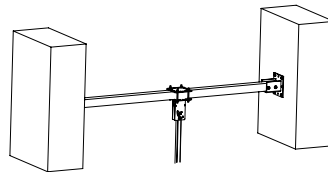

Code 20270

**STF 4**

Bracket kit for anchorage with supplied hinge. (3 m length)

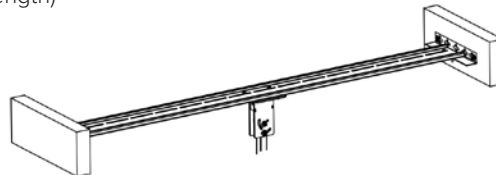

Code 20271

**STF 5**

Bracket kit for anchorage with omega beam.

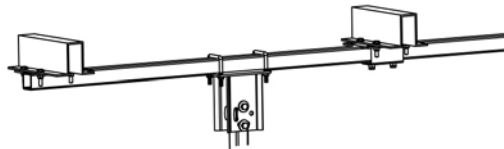

Code 20272

**STF 6**

Bracket kit for anchorage to joist under a windshield (2 m length)

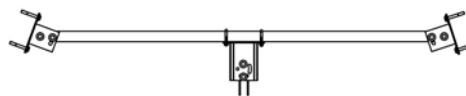

Cod.20746

**STF 7**

Bracket kit for installation on laminated beams

## THERMAL DESTRATIFICATION

### WELL-BEING AND ENERGY SAVING EVEN IN WIDE INDUSTRIAL AND COMMERCIAL ENVIRONMENTS THANKS TO CEILING FANS

**Adequate comfort conditions and air quality are key elements in a work environment.** In wide commercial and industrial spaces with very high ceilings, it is hard to ensure adequate heating during all working hours. The energy costs are high and the results are not very satisfying.

The heat generated by the heating systems (radiators, air-heaters, etc.) moves upwards in convective motion and stratifies near the ceiling, leaving the areas near the floor colder. In industrial depots, shopping centres, museums, or workshops, it often happens that, in order to keep 18 °C at “users’ level”, the air temperature near the ceiling exceeds 30-35 °C. Under these conditions, the well-being of those living the environment decreases, while the costs to keep the ideal temperature are rising.

**The solution to this problem is thermal destratification using ceiling fans.** If well-placed, ceiling fans create a perfect mix between warm air and cool air even at low speed, keeping a uniform temperature. This comes with all the advantages in comfort and effective reduction of energy consumption. Specific studies show that the savings provided by the application of thermal destratification systems in particular commercial and industrial environments can cover purchasing and installation costs in just 4 years.

Especially since ceiling fans are more often used during summertime **to eliminate stagnation and humidity and to allow adequate air circulation.**

**VORTICE has the ideal know-how, experience,**

**and range of products to install thermal destratification systems in wide environments.**

Our qualified technicians are at our clients’ disposal for designing and creating customised solutions, also using thermal-fluid-dynamic simulation systems. The pictures in these pages are taken from a simulation made by the VORTICE R&D department on a study commissioned by a client and later experimentally confirmed.

## INDUSTRIAL BUILDING EXAMINED: MODEL LAYOUT



NORDIK HVLS HYPERBLADE

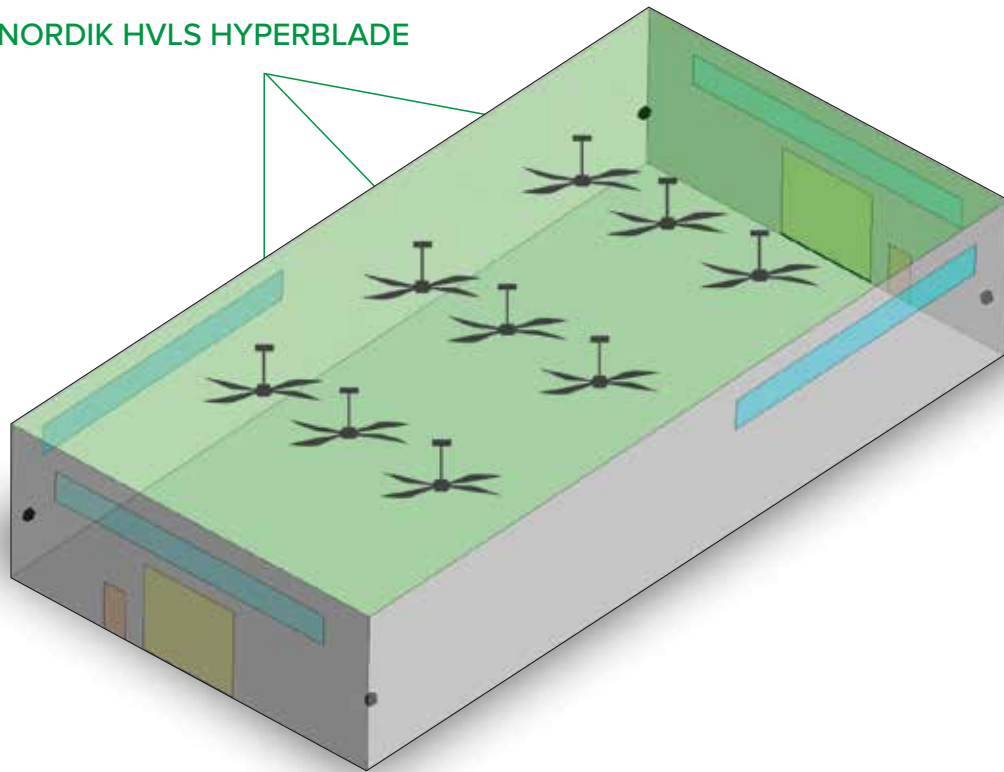

## 4 FAN HEATERS OF 12 KW HEATING CAPACITY (TOTAL 48 KW)

(FREE CONVECTION, CEILING FANS = OFF)

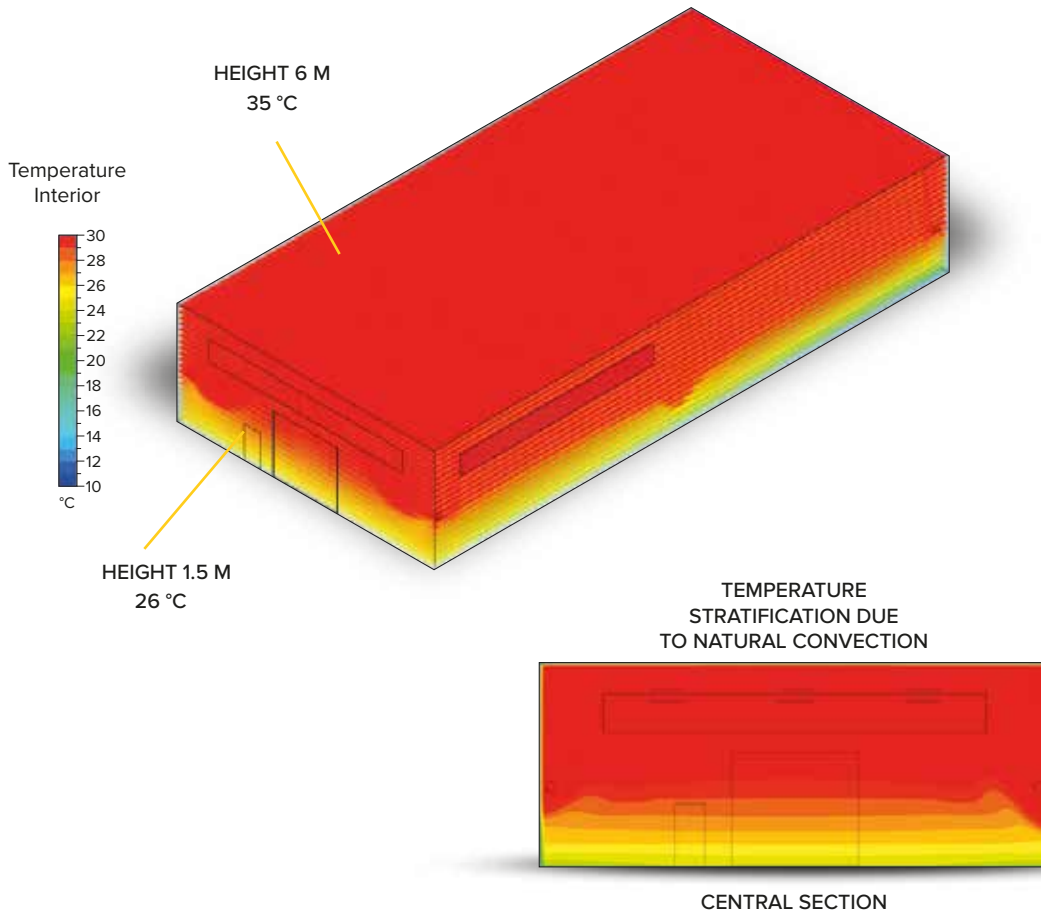

20

### **“STANDARD” INDUSTRIAL BUILDING (ONLY HEATING SYSTEM ON): DISTRIBUTION OF INTERNAL TEMPERATURE**

Simple heating system with 4 thermal fans, with a total power of 48 kW, manages to reach a minimum temperature of 20 °C inside the building, but characterised by an inefficient temperature stratification in height caused by natural convection.

## 4 FAN HEATER OF 9 KW HEATING CAPACITY (TOTAL 36 KW)

(CEILING FANS = ON)

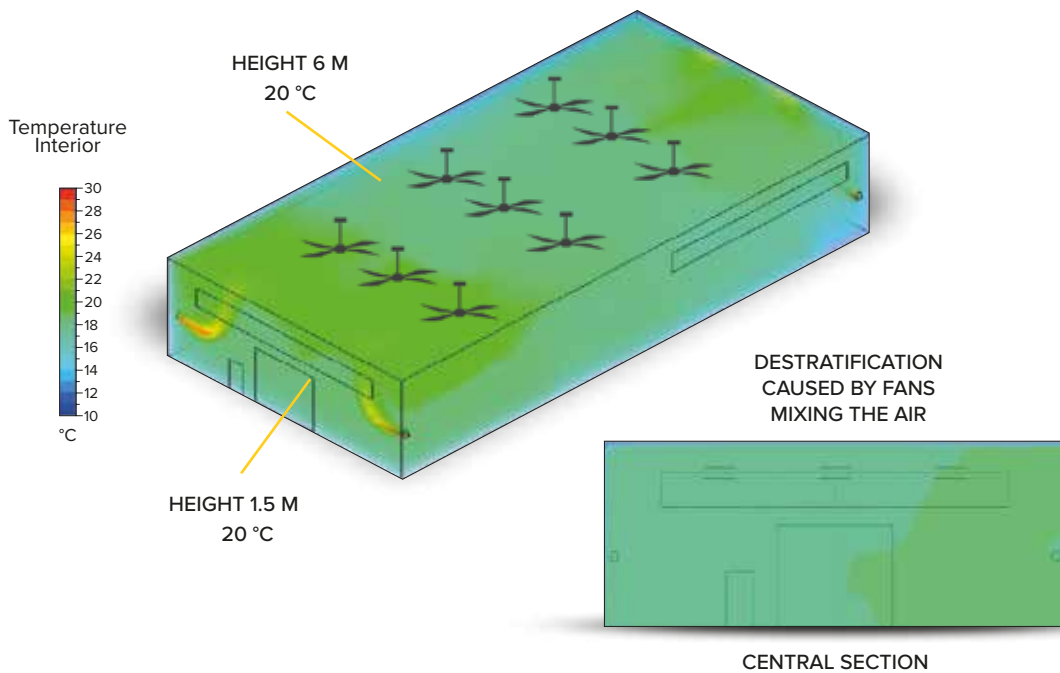

21

### DESTRATIFICATED AIR: INTERNAL TEMPERATURE DISTRIBUTION

Low-speed fan operation creates a uniformly heated and comfortable environment, reaching the desired temperature of 20 °C with reduced energy consumption levels.

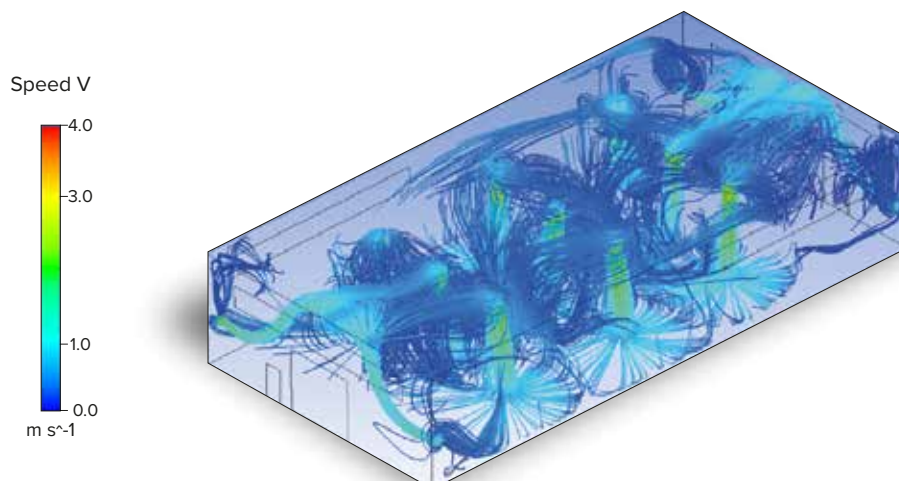

### AIR SPEED FLOW LINES DURING FAN OPERATION

Even at low speed, the fans can efficiently mix warm air and cool air without any side effects on the occupants in the building.





# VORTICE GROUP COMPANIES

## VORTICE S.P.A

Strada Cerca, 2  
District of Zoate  
20067 Tribiano  
(Milan) Italy  
Tel. (+39) 02 906991  
vortice.com  
V.A.T. IT 04474410968

## BUSINESS UNIT INDUSTRIAL

Via B. Brugnoli 3,  
37063 Isola della Scala  
(Verona) Italy  
Tel. (+39) 045 6631042  
vorticeindustrial.com  
V.A.T. IT 04474410968

## VORTICE LIMITED

Beeches House  
Eastern Avenue  
Burton on Trent  
DE13 0BB United Kingdom  
Tel. (+44) (0) 1283-49.29.49  
vortice.ltd.uk

## CASALS VENTILACIÓN AIR INDUSTRIAL S.L.

Ctra. Camprodon, s/n 17860  
Sant Joan de les Abadesses  
(Girona) Spain  
Tel. (+34) 972720150  
casals.com

## VORTICE LATAM S.A.

Bodega #6  
Zona Franca Bes Alajuela,  
Alajuela 20101  
Costa Rica  
Tel. (+506) 2201.6934  
vortice-latam.com

## VORTICE VENTILATION SYSTEM

(Changzhou) Co.LTD  
No. 388 West Huanghe Road  
Building 19, Changzhou  
Post Code: 213000 China  
Tel. (+86) 0519 88990150  
vortice-china.com

## VORTICE POLSKA

ul. Cybernetyki 19A,  
02-677 Warszawa  
Poland  
biuropolska@vortice.com  
vorticepolska.pl

The descriptions and illustrations in this catalogue are intended to be indicative and not binding. Without prejudice to the essential characteristics of the products described and illustrated here, VORTICE reserves the right to make, at any time and without notice, any changes to parts, aesthetic details or supply of accessories to its products that are deemed to be appropriate for improvement or for any construction or commercial requirement. This printout completely cancels and replaces all previous ones.

